



STOCKINGER.COM

STOCKINGER MANUFAKTUR

EICHENSTRASSE 15 · 82061 NEURIED · GERMANY · TEL: +49 89-7590 5828 · FAX: +49 89-7590 5830 · INFO@STOCKINGER.COM

EST. 1978
STOCKINGER
SAFETY FIRST CLASS



STOCKINGER for **BENTLEY**

LIMITED EDITION

■ ■ ■ HANDCRAFTED IN GERMANY



STOCKINGER FOR BENTLEY - CONTINENTAL

Dedicated to design, engineering and craftsmanship. Created in honour of the Bentley vision. The new "Stockinger for Bentley - Continental" exhibits sleek luxury in design and polished perfection in technology. Like its famous namesake, it combines secure technology with designer looks. The "Continental" will be limited to 200 safes.

As a Bentley is unmistakable, so too is a Stockinger safe. Hallmarks of luxury such as the leather linings and the brushed aluminium interior finish combine with the seven layer lacquer and design elements typical of Bentley interiors to create its exciting beauty. The "Continental" is an elegant jewellery safe, an attractive, secure environment for placing beautiful possessions - liberating them from wall safes and bank vaults.

TRADITION, VALUES AND CONTINUITY

People have always attempted to preserve objects of value. Over the course of history, the locksmith profession has become increasingly demanding. Today they are artists who combine both style and technical vision in their work.

At Stockinger, we are committed to this philosophy. We regard our craftsmanship as a gesture of appreciation to what is beautiful and valuable - and valuables should, of course, be secured as safely as possible.



STOCKINGER CRAFTSMANSHIP

Many people can build a safe but for us at Stockinger, our work really starts where theirs ends. Every safe has a security concept, which is the result of lengthy consideration coupled with experience and insight. Each safe combines a unique construction, special barrier materials, double boltwork and the patented Stocktronic keypad system. Stockinger safes meet the highest demands of German and International insurance companies and are entitled to carry the extremely high VDS security rating based on EN1143/1. Every single component as well as the finished product is subjected to stringent quality controls.

DESIGN AND FINISH

Every single Stockinger safe is a unique and bespoke masterpiece. The surface of each piece is carefully and conscientiously primed, painted and sanded during an 18-stage process of manufacture. This process takes several weeks and is completed with a finish of the finest carnauba wax, which produces a softer look with an unusual optical depth to the paint. The safe is available in all standard Bentley exterior paints, 10 Stockinger interior suedes and 3 wood veneer panels.

The Bentley handle itself weighs 3,5 kilograms and has been milled in a 16-hour process from a single block of brass. In 4 more refining steps, the grip has been sanded, polished, chromed and lacquered to provide the jewelled finish.

Complete with the Bentley "B" at the centre of the handle, the Stockinger "Continental" provides the ideal, secure environment for your valuables.



DEDICATION TO DETAILS

The finish on the drawers and on the safe door is identical to the Bentley dashboard texture, known as engine turning. Engine turning is a labour-intensive process, associated with high quality luxury items and is traditionally found in the racing cockpit interior of one of Bentley's earliest cars, the Bentley Blower. For the first time, the engine turning technique has been applied to the interior of a safe. The "Continental", with its 6 different trays, provides the ultimate storage solution for your jewellery. Whether it be large or small rings, brooches, earrings, wide or narrow necklaces, chokers, cufflinks or bangles, you will be able to present your jewellery at home in the style you are accustomed to.

Around 30 different teams of experts, from engineers and technicians to craftsmen and artists, are involved in the manufacture of the "Continental".

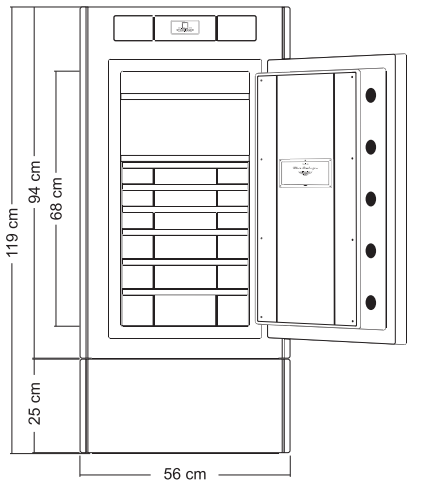
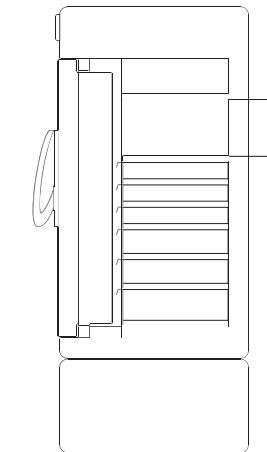
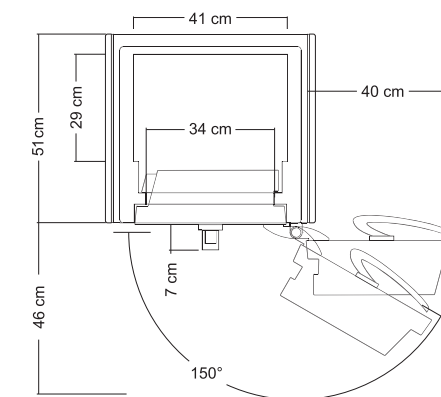

FACTS & FIGURES

Dimensions (H x W x D):	119 x 56 x 51 cm 47 x 22 x 20 inches
Weight:	approx. 485 kg / 1067 lbs
Volume:	approx. 95 dl.
Security grade:	EN 1143/VDS III
Locking mechanism:	Stocktronic
Interior:	3 drawers à 6 cm 2 drawers à 8 cm 1 drawer à 10 cm
Trays:	6 for watches and jewellery
Finish options:	All standard Bentley exterior paints, 10 suedes
Wood veneer panels:	Birds Eye Maple, Burr Walnut or Dark Stained Burr Walnut
Limited edition:	200 safes

UNCOMPROMISING RELIABILITY

The patented Stocktronic locking system guarantees security and extraordinary ease of use. The unique operating drawer with a concealed keypad is opened by applying slight pressure to the square of the Stockinger logo. Our Stocktronic can also be connected to any alarm system and can be programmed to trigger a "silent alarm", so in threatening situations you are able to set off an emergency signal simply by opening your safe in the normal way.

Stockinger safes have a multi-wall safe construction, which allows the lightest possible weight combined with a maximum security level. The bolt mechanism locks the safe on all four sides. Large pin locks provide additional protection against break-ins, and for aesthetic reasons are always chrome-plated. All Stockinger safes have an emergency bolt mechanism, which permanently bolts the safe if an attempt is made to open it by force.

All our safes are subject to a tight quality control procedure. This quality control and our strict guidelines for production ensure high standards of reliability.